

HER1601CT THRU HER1608CT

GLASS PASSIVATED HIGH EFFICIENCY RECTIFIER



REVERSE VOLTAGE: 50 to 1000 VOLTS
FORWARD CURRENT: 16.0 AMPERE

FEATURES

- Plastic package has Underwriters Laboratory Flammability Classification 94V-0 utilizing Flame Retardant Epoxy Molding Compound.
- Low power loss, high efficiency.
- Low forward voltage, high current capability
- High surge capacity.
- Ultra fast recovery times, high voltage.
- Exceeds environmental standards of MIL-S-19500/228

MECHANICAL DATA

Case: Molded plastic, TO-220

Epoxy: UL 94V-0 rate flame retardant

Terminals: Leads solderable per MIL-STD-202 method 208 guaranteed

Polarity: As marked

Mounting position: Any

Weight: 0.08ounce, 2.24gram

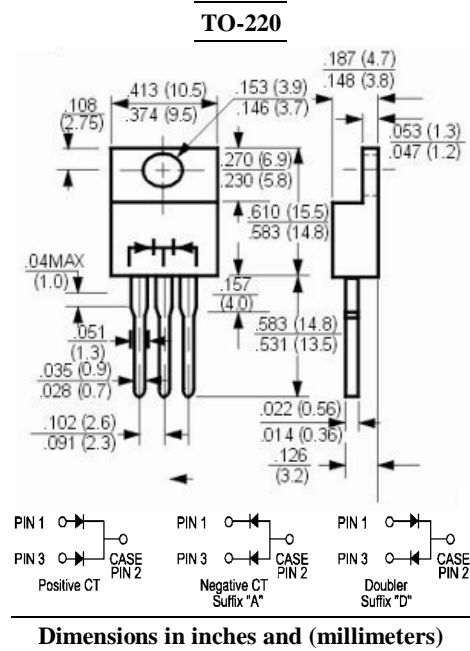

Maximum Ratings and Electrical Characteristics

Ratings at 25°C ambient temperature unless otherwise specified.

Single phase, half wave, 60Hz, resistive or inductive load.

For capacitive load, derate current by 20%.

	Symbols	HER1601CT	HER1602CT	HER1603CT	HER1604CT	HER1605CT	HER1606CT	HER1607CT	HER1608CT	Units	
Maximum Recurrent Peak Reverse Voltage	V_{RRM}	50	100	200	300	400	600	800	1000	Volts	
Maximum RMS Voltage	V_{RMS}	35	70	140	210	280	420	560	700	Volts	
Maximum DC Blocking Voltage	V_{DC}	50	100	200	300	400	600	800	1000	Volts	
Maximum Average Forward Rectified Current at $T_C=100^\circ\text{C}$	$I_{(AV)}$	16.0								Amp	
Peak Forward Surge Current, 8.3ms single half-sine-wave superimposed on rated load (JEDEC method)	I_{FSM}	125								Amp	
Maximum Forward Voltage at 8.0A and $T_A=25^\circ\text{C}$	V_F	1.0			1.3		1.7			Volts	
Maximum Reverse Current at $T_A=25^\circ\text{C}$ at Rated DC Blocking Voltage $T_A=125^\circ\text{C}$	I_R	10.0				500					uAmp
Typical Junction Capacitance (Note 1)	C_J	80					50				pF
Maximum Reverse Recovery Time (Note 2)	T_{RR}	50					80				nS
Typical Thermal Resistance (Note 3)	$R_{\theta JC}$	3								$^\circ\text{C}/\text{W}$	
Operating and Storage Temperature Range	T_J, T_{stg}	-55 to +150								$^\circ\text{C}$	

NOTES:

- 1- Measured at 1 MHz and applied reverse voltage of 4.0 VDC.
- 2- Reverse Recovery Test Conditions: $I_F=0.5\text{A}$, $I_R=1\text{A}$, $I_{RR}=0.25\text{A}$.
- 3- Thermal Resistance from Junction to Case Per Leg Mounted on Heatsink.

HER1601CT THRU HER1608CT

GLASS PASSIVATED HIGH EFFICENCY RECTIFIER



RATINGS AND CHARACTERISTIC CURVES

FIG.1- REVERSE RECOVERY TIME CHARACTERISTIC AND TEST CIRCUIT DIAGRAM

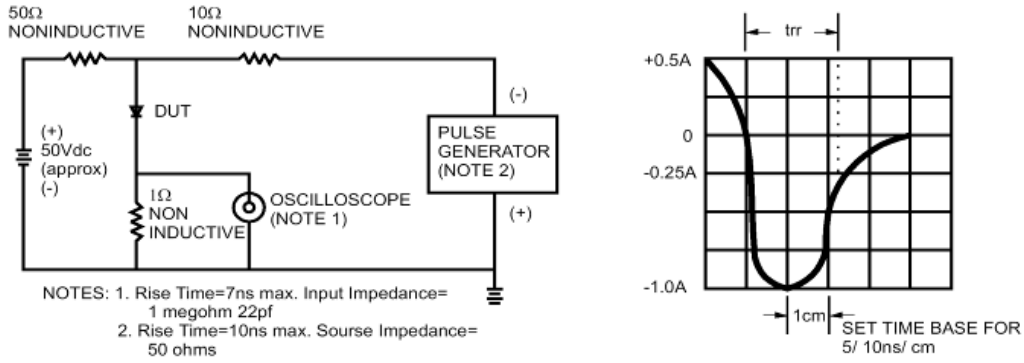

FIG.2- MAXIMUM FORWARD CURRENT DERATING CURVE

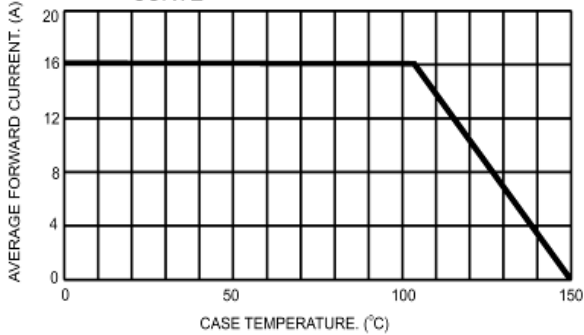

FIG.3- TYPICAL REVERSE CHARACTERISTICS PER LEG

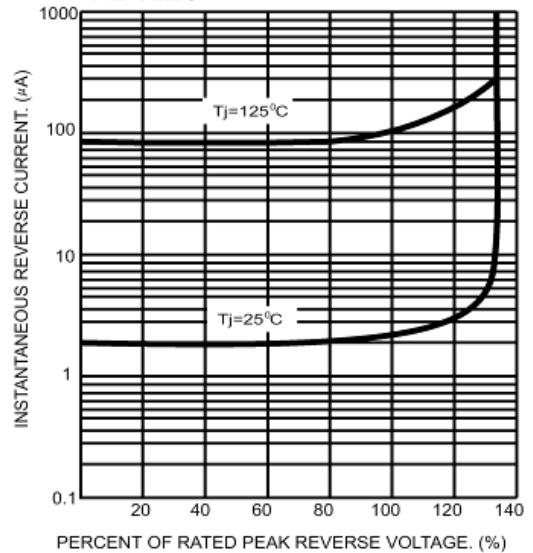

FIG.4- MAXIMUM NON-REPETITIVE FORWARD SURGE CURRENT PER LEG

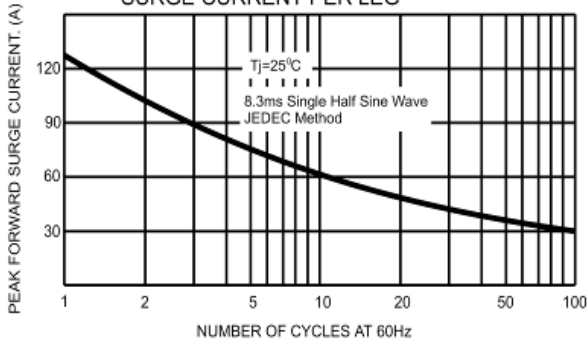

FIG.6- TYPICAL FORWARD CHARACTERISTICS PER LEG

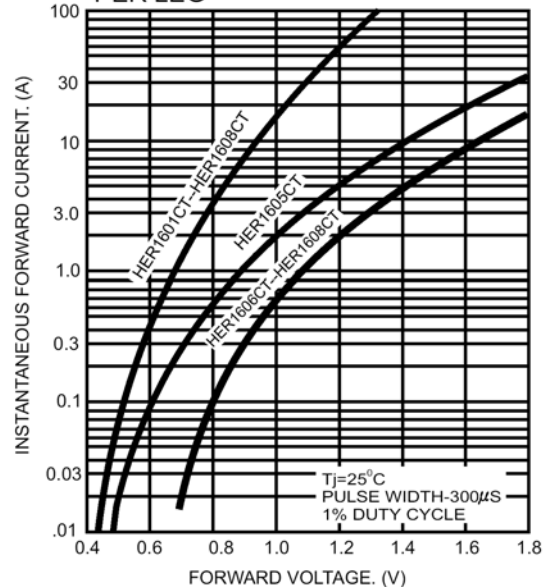

FIG.5- TYPICAL JUNCTION CAPACITANCE PER LEG

