

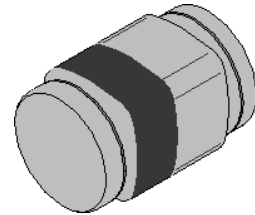

High-speed switching diode

Features

1. Saving space
2. Fits onto SOD 323/SOT 23 footprints
3. Micro Melf package



Applications

Extreme fast switches

Construction

Silicon epitaxial planar

Absolute Maximum Ratings

$T_j=25$

Parameter	Test Conditions	Type	Symbol	Value	Unit
Repetitive peak reverse voltage			V_{RRM}	100	V
Reverse voltage			V_R	75	V
Peak forward surge current	$t_p=1 \mu s$		I_{FSM}	2	A
Repetitive peak forward current			I_{FRM}	450	mA
Forward current			I_F	200	mA
Average forward current	$V_R=0$		I_{FAV}	150	mA
Power dissipation			P_V	500	mW
Junction temperature			T_j	175	
Storage temperature range			T_{stg}	-65~+175	

Maximum Thermal Resistance

$T_j=25$

Parameter	Test Conditions	Symbol	Value	Unit
Junction ambient	on PC board 50mm x 50mm x 1.6mm	R_{thJA}	500	K/W



Electrical Characteristics

$T_j=25$

Parameter	Test Conditions	Type	Symbol	Min	Typ	Max	Unit
Forward voltage	$I_F=5\text{mA}$	MCL4448	V_F	0.62		0.72	V
	$I_F=10\text{mA}$	MCL4148	V_F		0.86	1	V
	$I_F=100\text{mA}$	MCL4448	V_F		0.93	1	V
Reverse current	$V_R=20\text{V}$		I_R			25	nA
	$V_R=20\text{V}, T_j=150$		I_R			50	μA
	$V_R=75\text{V}$		I_R			5	μA
Breakdown voltage	$I_R=100\ \mu\text{A}, t_p/T=0.01, t_p=0.3\text{ms}$		$V_{(BR)}$	100			V
Diode capacitance	$V_R=0, f=1\text{MHz}, V_{HF}=50\text{mV}$		C_D			4	pF
Rectification efficiency	$V_{HF}=2\text{V}, f=100\text{MHz}$		η_R	45			%
Reverse recovery time	$I_F=I_R=10\text{mA}, i_R=1\text{mA}$		t_{rr}			8	ns
	$I_F=10\text{mA}, V_R=6\text{V}, i_R=0.1 \times I_R, R_L=100$		t_{rr}			4	ns

Characteristics ($T_j=25$ unless otherwise specified)

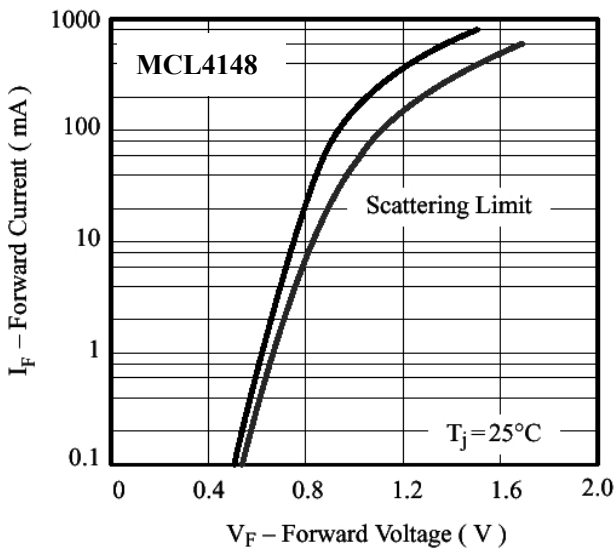

Figure 1. Forward Current vs. Forward Voltage

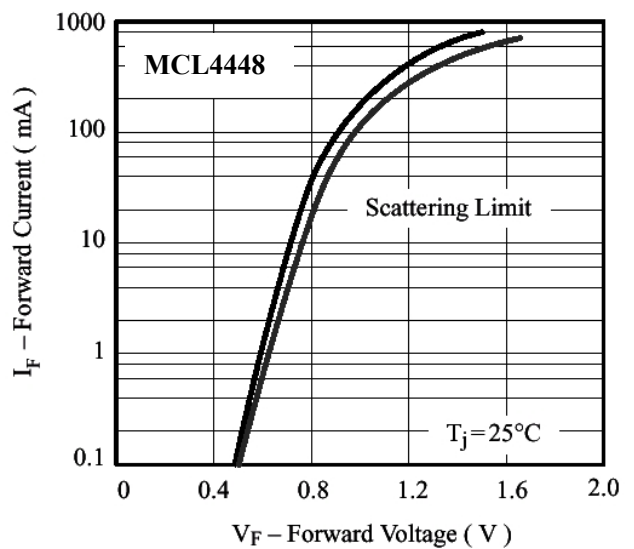

Figure 2. Forward Current vs. Forward Voltage

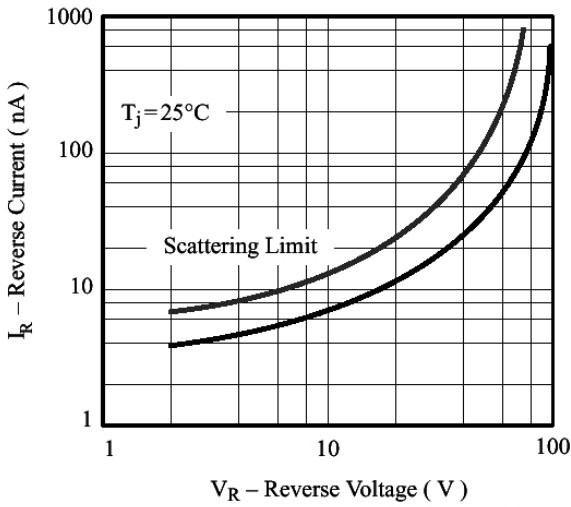

Figure 3. Reverse Current vs. Reverse Voltage

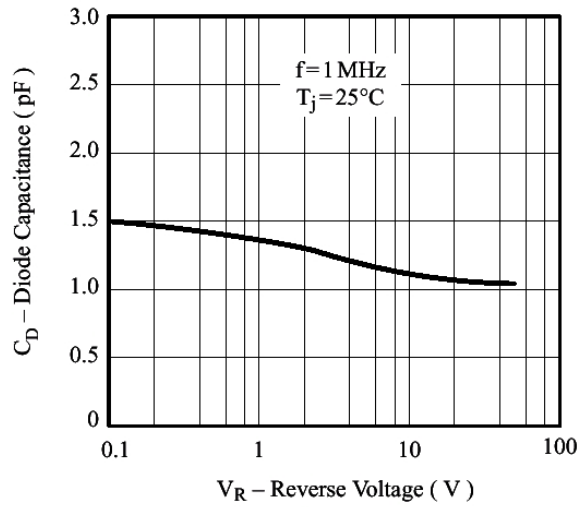
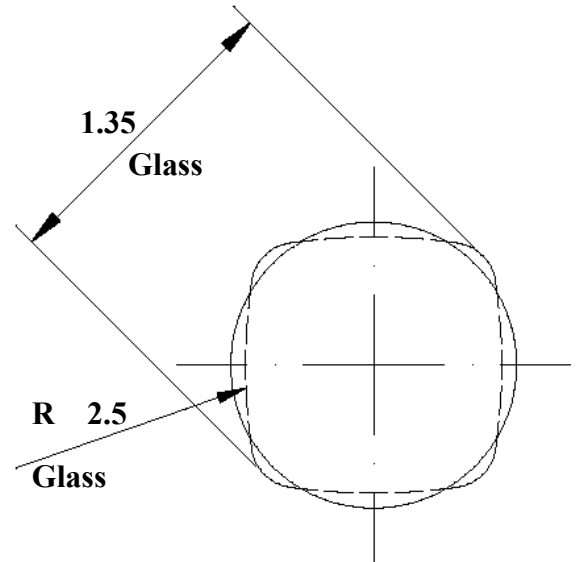
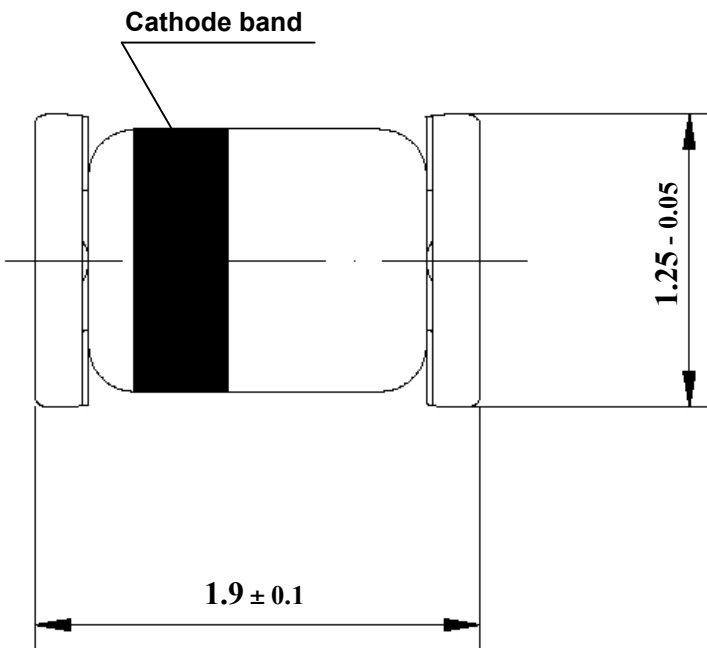

Figure 4. Diode Capacitance vs. Reverse Voltage

Dimensions in mm



Glass Case

Micro Melf